

A Novel Adaptive Multimedia Delivery Algorithm for Increasing User Quality of Experience during Wireless and Mobile E-learning

Vasile Horia Muntean and Gabriel-Miro Muntean, *Member, IEEE*

Abstract — Multimedia content is distributed via all types of networks to viewers found in a variety of locations and using different types of devices. Increasing the performance of multimedia stream delivery requires overcoming many technological challenges, all of them having a direct effect on the user perceived quality of experience. The quality of experience influences in turn the quality of any e-learning process. This is as users in general and learners in particular are becoming increasingly quality-aware in their expectations. Therefore delivering a good quality video stream as a part of any e-learning process is very important. This paper proposes a new adaptive multimedia delivery algorithm which can be used in the context of e-learning. The Dynamic Quality Oriented Adaptation Scheme (D-QOAS) adapts the multimedia content sent based on both user preferences and network conditions, while adjusting dynamically its adaptation policy during delivery. Simulation results show that for different user profiles and various network conditions the improvement in end-user perceived quality is significant. Important benefits are obtained in terms of the total number of simultaneous users and in the link utilization, as well as in quality as measured by some video quality metrics.

Index Terms — dynamic content adaptation, e-learning, multimedia, rate control, wireless networks

I. INTRODUCTION

E-LEARNING has become an important service offered over the Internet and despite the current economic downturn, is expected to increase in popularity [1]. In this context the global e-learning market which was worth \$8 billion in 2006 is expected to grow to \$13 billion by 2011 [2]. A recent study on e-learning in Europe [3] which highlighted future trends indicated that one of the most important is the provision of suitable services to people without broadband internet access, in rural or remote areas, potentially involving wireless connectivity.

Lately increased number of users is accessing learning

Manuscript received April 9, 2009. The support of Enterprise Ireland, Proof of Concept and Science Foundation Ireland Research Frontiers programmes is gratefully acknowledged.

A Novel Adaptive Multimedia Delivery Algorithm for Increasing User Quality of Experience during Wireless and Mobile E-learning

V. H. Muntean is with the Performance Engineering Laboratory, Dublin City University, Dublin 9, Ireland (e-mail: horia@eeng.dcu.ie).

G.-M. Muntean is with the Performance Engineering Laboratory, Dublin City University, Dublin 9, Ireland (e-mail: munteang@eeng.dcu.ie).

content via wireless networks and by using mobile devices. Most content is rich media-based and often puts significant pressure on the existing networks in order to support high quality of delivery. The problem of supporting high quality multimedia streaming is getting even more difficult when delivering multimedia over wireless LANs. This is as wireless technologies offer lower bandwidth and their service is highly affected by environmental factors, traffic load and number of clients, as well as their location and mobility patterns. In this context, offering a solution for improving user quality of experience regardless of users' speed and mobility pattern is highly important. Additionally during multimedia delivery in the context of e-learning, there are some extra parameters that should be considered in relation to the user profiles in order to support a user-oriented solution.

This paper introduces a novel solution for adaptive multimedia streaming over IEEE 802.11 Wireless LANs with focus on mobile e-learning. The proposed Dynamic Quality Oriented Adaptation Scheme (D-QOAS) is a user-oriented adaptation mechanism that dynamically adapts the multimedia content sent based on user preferences and network conditions. By employing this algorithm, an increased number of simultaneous learners can be accommodated while maintaining the perceived quality levels above their individual good quality thresholds. This is done by dynamically modifying the adaptation policy during delivery, increasing or decreasing the granularity of the adaptation for some users, based on their preferences and actual network conditions.

D-QOAS performs an optimal dynamic multimedia content management according to end-user profile, knowledge level, goals, preferences as well as network conditions in order to support higher end-user quality of experience during the learning process.

The paper is structured as follows. Section II presents some existing adaptive solutions and the progress done in the e-learning area, while section III describes the system architecture its main modules. Section IV presents the adaptation algorithm – D-QOAS and section V describes the testing environment and presents the results. Conclusions are drawn in section VI.

II. ADAPTIVE SOLUTIONS FOR MULTIMEDIA DELIVERY

Much research work has been done in the area of adaptive streaming-based schemes. Existing adaptive solutions such as TCP-Friendly Rate Control Protocol (TFRC) [4] and the enhanced Loss-Delay Adaptation Algorithm (LDA+) [5] support certain level of multimedia quality in variable network delivery conditions, but they are mainly designed to offer good results when streaming multimedia over wired networks only. Using these algorithms over wireless networks often leads to results in medium/poor multimedia quality range as they do not include any end-user perceived quality assessment in the adaptation process.

One of the authors has already proposed the Quality Oriented Adaptation Scheme (QOAS), an adaptive streaming solution initially developed for broadband wired networks [6], but which also obtained very good results when it was used to deliver multimedia streams over wireless networks [7]. QOAS considers an estimation of end-user perceived quality as an active factor in the adaptation.

The area of network-oriented learning, known also as e-learning, is growing rapidly. Considering this interest and the diversity of the users, e-learning databases are becoming very rich in multimedia content. Some solutions were developed to adapt the content to user preferences and network conditions in the same time, but only static content adaptation was successful to date [8, 17]. Dynamic adaptation of multimedia content is the next step as web-based learning is using more video resources in order to provide higher user quality of experience levels.

In the past few years, a variety of solutions have been proposed for streaming scalable multimedia content over wireless networks [9] or wireless ad-hoc networks [10]. Among these, the adaptive algorithms that operate at the level of layers [10] or objects [11], fine-granular scalability schemes [12] and perception-based approaches [13] are most suitable for further research considering the results obtained. However none of these algorithms considers in conjunction user learning goals and interests as well as network delivery conditions.

III. SYSTEM ARCHITECTURE

Figure 1 presents the architectural framework for the Performance-Aware Multimedia-based Adaptive Hypermedia (PAMAH), which enhances the classic Adaptive Hypermedia System architecture by including performance and QoS aspects in relation to adaptive multimedia content delivery. PAMAH supports the delivery of high quality personalised educational content to e-learners via heterogeneous networks. Its goal is to optimise users' QoE and their learning outcomes by automatically adapting content and navigational support based on both user interests and knowledge levels and current network delivery conditions.

The block-level architecture of the proposed system is

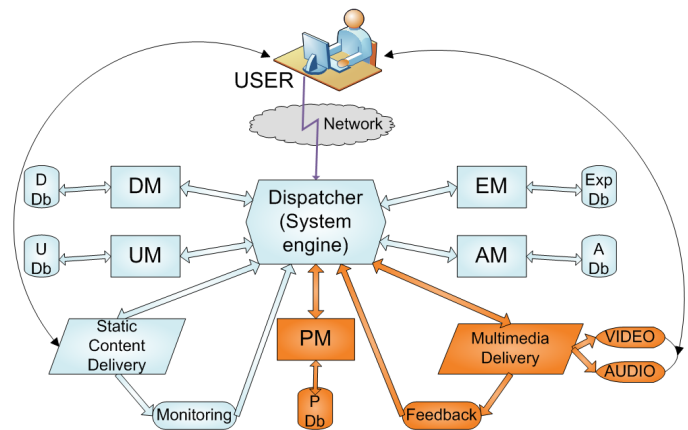

Figure 1 - Block-level system architecture

presented in Figure 1. This paper focuses on the highlighted parts, which are in charge with the rich-media content delivery.

This architectural framework for the PAMAH adaptive web-based system maintains five models: Domain Model (DM), User Model (UM), Experience Model (EM), Adaptation Model (AM) and Performance Model (PM). Every model has attached its own database, used to store information specific to that model: D Db, U Db, Exp Db, A Db and P Db.

The Domain Model is designed to store the educational content, being organized in a hierarchical structure of concepts, amongst which logical relationships exist. A concept can be identified as a section of text, an audio file, a video clip, etc. All together with a set of rules, they form the educational units.

The User Model is built and maintained by the system. Here some user-related parameters are assessed: user knowledge levels, preferences, goals. The multimedia delivery considers these parameters in the adaptation process, improving user quality of experience.

The Experience Model is specially designed to assess user quality of experience, by storing information about user preferences of media or activities, learning goals, interaction preferences, preferred type of feedback, etc. Some of the stored information are behavior characteristics (behavior trackers) and others are experience dependent (experience trackers).

The role of the Adaptation Model is to decide on personalization and performance adaptations to the content, based on the information gathered by the System Engine from PM and UM.

The Performance Model, performs real time monitoring for different factors that influence network delivery (e.g. throughput, RTT, QoS metrics, etc).

All these models are controlled and interconnected through the Dispatcher, or the System Engine. The Dispatcher uses information stored in different models and dynamically builds a list of rules which will be used further by the delivery mechanisms, both static content delivery and multimedia delivery. Except the parameters and rules offered to Multimedia Delivery module by the Dispatcher, there are other network-related parameters that are considered when

rich media-content fragments are transmitted. This novel PAMAH architecture is meant to improve the final outcome of the e-learning process by using dynamic adaptation techniques that consider both network-related and user-related factors.

In this paper the adaptive multimedia delivery is discussed in more details. Multimedia Delivery block implements the D-QOAS adaptation algorithm presented in the next section, considering the input from the Dispatcher. The Feedback Module creates a report that summarizes the delivery conditions and the user feedback for the delivered stream. This report is sent to the Dispatcher which is extracting the important parts and forwards them to the concerned modules. The network-related information is forwarded to the PM which is checking the personal database for any resembling patterns. After placing the current parameters in a certain category, the Performance Module generates a report for the Dispatcher. Taking into account the reports from the rest of the modules, the dispatcher builds a list of rules that will be sent to Multimedia Delivery block, as a new input for the adaptation algorithm. As the e-learning process itself is highly dynamic, D-QOAS algorithm is designed to keep up with the continuously changing conditions and parameters involved in the e-learning process to improve end-user quality of experience by adjusting dynamically its adaptation policy.

IV. D-QOAS ALGORITHM

A. Overview

D-QOAS is developed to increase end-user quality of experience while also enabling higher number of simultaneously connected clients to communicate. In the system architecture presented in Figure 1, the Adaptation Model performs real-time bandwidth estimation for every user involved in the e-learning process. Based on this bandwidth estimation and also on the additional information from other models, the System Engine decides if a video stream is suited or not for a certain user. If the proper conditions for a streaming session are satisfied then a specific list of rules is built by the Dispatcher and forwarded to the N-Level Builder Module. Here, considering user requirements, the user-specific streaming parameters are computed and the session starts.

B. D-QOAS Principle

D-QOAS enhances QOAS [8] by adding different user QoE expectation levels in the adaptation process. Consequently, D-QOAS will perform a differentiate treatment of the users, adaptive process based not only on network conditions, but also on their requirements in terms of their QoE. Unlike QOAS, which uses static potential bitrate adaptive levels, D-QOAS dynamically adapts them to suit the delivery process.

Figure 2 illustrates the major blocks of the D-QOAS algorithm for improving user quality of experience during mobile and wireless e-learning, deployed on the PAMAH architectural structure described in section III.

On the client side there is a Decoding & Playing Module whose role is to decode and afterwards play the adapted video stream received from the server. Connected to this module is a

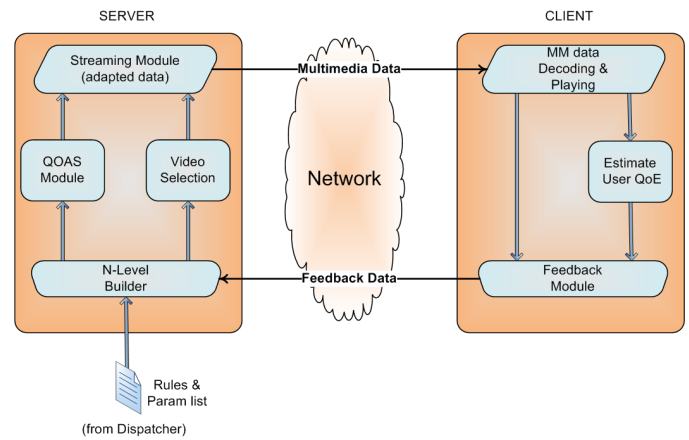

Figure 2 - Dynamic QOAS adaptation algorithm

dedicated module that performs estimation about the end-user perceived quality. The Feedback Module is monitoring delivery-interest parameters such as loss rate, delay and jitter and also assesses the quality of delivery, sending short reports to the server. These reports contain network-related information and user-specific parameters used on the server side by the Dispatcher (represented in Figure 1) and by the N-Level Builder Module. Based on this report the Dispatcher will update the new list of rules and parameters specific for every user and will also update the relevant system databases (A Db and U Db). The list of rules and parameters consists of user-related information (the QoE expectation levels for every user) and session-specific information (which users will be considered for a streaming session, video file to be selected for the current session, video metadata, etc).

On the server side, three important phases are described:

1. Initial Level Building

The initial level building is invoked when a new user in the system is requesting a multimedia stream. Because for this new user the Estimation Module has not established yet the QoE expectation level, the level building is done statically directly by the QOAS Module. This new user will appear in the list of rules and parameters with his QoE expectations level set to 0. When N-Level Builder Module is analyzing the list and discovers the new user, it will forward a level request to QOAS Module for building the static levels just for this user.

For a new user U_k the QOAS algorithm builds M potential levels of quality: $L_1 L_2 \dots L_j \dots L_M$. L_1 represents a low bitrate while L_M represents the maximum bitrate (the video bitrate).

During the session, the system estimates the QoE expectation level for this user and the quality levels will be updated dynamically. After QoE estimation, one of the inputs in the rules list corresponding to this user indicates a video-quality level which represents the acceptable quality expectation level associated to this user. Considering this level, D-QOAS algorithm is building another set of levels, this time having new limits, other than the static levels: between the user QoE expected level and the maximum video level, L_M . Like this, a user oriented dynamic adaptation is performed. The procedure for this is presented below.

2. Updating Dynamically the Quality Levels

The procedure for dynamically update the levels for a user involved in a streaming session can be triggered by different causes: changes in the network parameters, users detaching/attaching to the network, updates of QoE expectation level for certain users, etc. The decision for dynamic update of levels is taken by the N-Level Builder based on the information received from the Dispatcher (the list of rules and parameters) and from the Feedback Module. The user QoE expected level found in the rules and parameters is unique for every user and represents the minimum video bitrate that will be transmitted for that user.

For user U_k , after the QoE estimation is performed on the client side, the expectation level is decided to be M_k . This level is situated in the interval defined by the minimum and maximum static levels, L_1 and L_M . Once M_k is known, the N-Level Builder Module proceeds and rebuilds the adaptation levels for user U_k . Every time the user QoE expectation level is changing, the N-Level Builder will initiate the procedure for dynamically update the levels.

While a new user has a fixed number of levels, M , a user who has a QoE expectation level assigned in the list, will have a variable number of levels, N . This value can vary depending on the network conditions, bandwidth estimation, user QoE expectation level and the number of users. By using the user-specific levels of quality the algorithm is able to control better the video quality adjustment. This is performed in order to increase end-user perceived quality since it was demonstrated that viewers tend to prefer a controlled reduction in the quality of the streamed multimedia content than random losses [14].

3. Adaptation Mechanism

Considering P users involved in the e-learning session: $U_1 U_2 U_3 \dots U_k \dots U_{P-1} U_P$, for every user there is a QoE expectation level specifying the expected quality by that user: $M_1 M_2 M_3 \dots M_k \dots M_{P-1} M_P$.

For any user U_k the algorithm builds the dynamic levels by dividing the amount of bandwidth between M_k and L_M into intervals. The division depends on the network QoS parameters which are considered in real-time. After this step, the QOAS Module is tuned on these new adaptation levels of quality obtained for user U_k . The Streaming Module is responsible for streaming the selected video file according to the user-specific levels. Video selection is performed by the Video Selection Module, based on the information presented in the list of rules and parameters.

Rate control adaptation process is applied by the N-Level Builder Module whenever media-rich content fragments transmitted needs to adapt their bit rate to match the network parameters and user requirements. Delivery of these fragments usually requires significant network resources and lasts over a longer period of time in which delivery conditions can vary. In this case, random losses have a greater impact on the end-user perceived quality than a controlled reduction in quality.

In conclusion D-QOAS dynamically varies the quantity of information transmitted to suit the delivery conditions and user interests. For example, after a period of increased traffic load on the network, when the stream was adapted and set to

be delivered at low bit rates, if any improvements in network conditions are detected, the N-Level Builder Model will increase step-by-step the bitrate, according to the user-specific levels, improving therefore user-perceived quality. On the other hand, if at a certain point the network conditions are degrading (increase in the background traffic, new e-learning users) then D-QOAS will rebuild the dynamic levels for every user. The new levels will have a smaller granularity and as a consequence the maximum level considered might decrease.

V. TEST RESULTS

A. Simulation Models and Setup

The proposed algorithm is tested using Network Simulator with the NOAH (No Ad-Hoc) patch installed [15]. NOAH implements the direct wireless routing between base stations and mobile devices. The simulation models used are Dynamic QOAS, QOAS and a non-adaptive solution. Test scenarios will be deployed using the simulation setup, which involves a wired-cum-wireless network, presented in Figure 3.

Node 0 is considered to be the server, while nodes 3, 4, 5, 6 and 7 are the users. The server will stream multimedia traffic to five mobile users, who can attach/detach to the network at the same time or randomly. IEEE 802.11b WLAN covering nodes 2, 3, 4, 5, 6 and 7 and a wired LAN with a bottleneck link 0-1 are deployed. The bottleneck link was fixed to a value slightly greater than $\sum(M_k)$ (the sum of minimum QoE expectation levels for every user). In our case, considering the five users, the link bandwidth was set up at 3.8Mbps. The delay for this link is set to 2 ms.

For every user involved in the adaptation process some minimum quality-levels for the video stream were defined, as seen in Table 1.

The Dynamic QOAS algorithm implemented for testing uses specific adaptation rules for every user, considering user QoE expectation levels described in Table I and the network conditions. Depending on the number of users connected to the network and the actual network conditions these rules can change during the transmission of a multimedia stream so that the system can serve as many users as possible while still keeping the quality above their acceptance limit.

QOAS algorithm used here is deployed with five user QoE expectation levels, the lowest level being equal to the smallest quality level from the considered users (in our case the lowest level is 0.3 Mbps, the expected QoE level for U_1). The highest level is the actual bitrate of the original video used (1.5 Mbps).

For the non-adaptive streaming three scenarios were considered: every client will try to obtain the maximum bitrate (1.5 Mbps), the average bitrate (0.9 Mbps) or the lowest bitrate (0.3 Mbps).

The multimedia clip used has an average/low motion level with a resolution of 840x480 and a frame rate of 23.97fps.

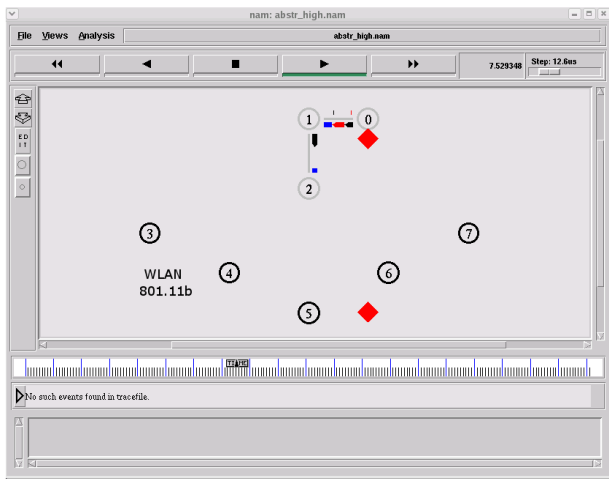

Figure 3 - Test topology - NS graphical interface

TABLE I
USER-SPECIFIC THRESHOLDS FOR VIDEO QUALITY

User	Minimum expected quality level
U ₁	0.3 Mbps
U ₂	0.6 Mbps
U ₃	1.0 Mbps
U ₄	0.8 Mbps
U ₅	0.45 Mbps

B. Simulation Scenarios and Performance Assessment

A number of simulation scenarios including multiple users and loaded network conditions determined by background traffic are run. Maximum number of users considered here is five. This number of clients was chosen because it enabled all considered streaming approaches to offer the clients a multimedia stream around half the original encoding movie bitrate in the current simulation conditions. Performance is assessed in terms of end-user perceived quality, average link utilisation and average loss for the three streaming methods. Using a quality assessment tool developed within the Performance Engineering Laboratory at Dublin City University, Ireland, the estimated user perceived quality of the streaming was measured using VQM and PSNR metrics.

C. Results and Analysis

Figure 4 presents the throughput of the QOAS algorithm when 5 users are requesting a multimedia stream on different periods of time. It can be observed that even if the adaptation process improves quality of experience for all users involved in the streaming process compared to other solutions as also reported in [7] and [16], the algorithm is balanced and offers almost the same average stream quality for every user regardless of their characteristics. As some of the users involved in the E-learning process might have a higher QoE expectation level, their quality of experience will be affected negatively.

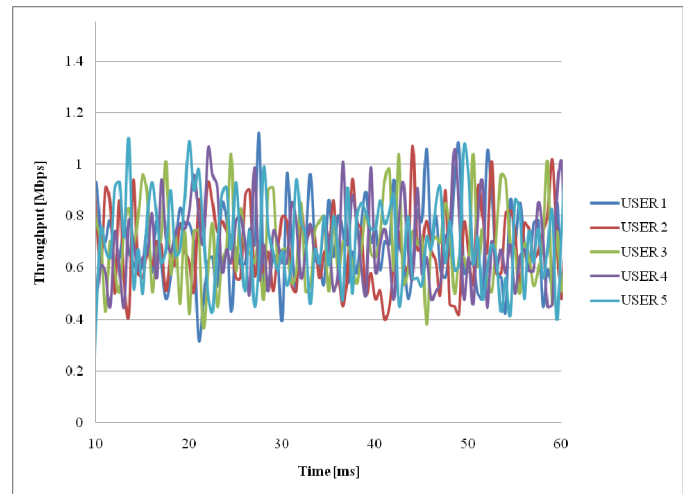

Figure 4 - Streaming session throughput with QOAS for 5 connected homogenous users

The same simulation conditions are used when Dynamic QOAS is deployed. The results are presented in Figure 5. It can be noticed that the user QoE expectation level represents a threshold for the video streaming throughput. This way the overall quality of experience for every user increases.

For the non-adaptive method (NoAd) we have considered the three scenarios specified and the results show that if the transmission rate is set to the maximum rate, only two users out of five can be served at the quality of experience expected by these users. If the quality is set to medium then the number of potential users increases, but still there will be an inefficient bandwidth use.

For the non-adaptive method (NoAd) we have considered the three scenarios specified and the results show that if the transmission rate is set to the maximum rate, only two users out of five can be served at the quality of experience expected by these users. If the quality is set to medium then the number of potential users increases, but still there will be an inefficient bandwidth use.

Table 2 presents the average throughput for every user receiving the multimedia stream considering all three simulation models. It can be observed that for NoAd method only 4 users can be served, as the loss rate is too high for the fifth. Also, the non-adaptive method provides an acceptable level of quality of experience for 3 users only in this setup. QOAS algorithm adapts the stream so that every user receives approximately the same amount of information. Being very efficient in terms of link utilization, QOAS provides the level of QoE expected to three out of five users only.

The proposed algorithm – D-QOAS – performs the dynamic adaptation according to user QoE expectation level and the current network conditions obtaining very good results. Using D-QOAS all five users are situated above their QoE expectation level, which means an important improvement in the overall quality of experience for every user.

In terms of link utilization, because of the dynamic adaptation performed, the proposed algorithm obtains very good results (over 96%). For the considered simulation testbed presented here, the link utilization obtained using D-QOAS was 99.8%.

TABLE 2
AVERAGE THROUGHPUT PER USER

	U_1	U_2	U_3	U_4	U_5
	[Mbps]	[Mbps]	[Mbps]	[Mbps]	[Mbps]
DQOAS	0.431	0.786	1.176	0.879	0.573
QOAS	0.766	0.726	0.712	0.697	0.710
NoAd 1	0.900	0.900	0.900	0.900	0.0
NoAd 2	1.500	1.500	0.0	0.0	0.0
NoAd 3	0.300	0.300	0.300	0.300	0.300

The link utilization was calculated between second 9.5 and second 61, when all five users were connected to the streaming server.

Quality assessment was performed in terms of PSNR and VQM for all multimedia delivery methods discussed. The results confirm that D-QOAS offers a user quality above the acceptable user QoE expectation level and in the limits of the “fair” PSNR range, outperforming the other schemes considered.

The results show that the Dynamic QOAS performance in terms of end-user perceived quality of experience is improved in comparison with QOAS and non-adaptive delivery.

VI. CONCLUSIONS AND FURTHER WORK

This paper proposes a new adaptive multimedia delivery algorithm which can be used in the context of e-learning. The Dynamic Quality Oriented Adaptation Scheme (D-QOAS) adapts the multimedia content sent based on both user preferences and network conditions, while adjusting dynamically its adaptation policy during delivery. Testing results show that compared with QOAS and a non-adaptive algorithm, the end user perceived quality has improved in terms of expected user quality of experience. Also there is an increase in the total number of simultaneous clients served as well as an increase in the link utilisation.

Further work implies refining D-QOAS as well as building a practical prototype for this system as subjective tests are needed to validate the preliminary results obtained by simulation. Studying different types of loss that can occur in a wired-cum-wireless network and fine tuning the adaptation to these is also envisaged.

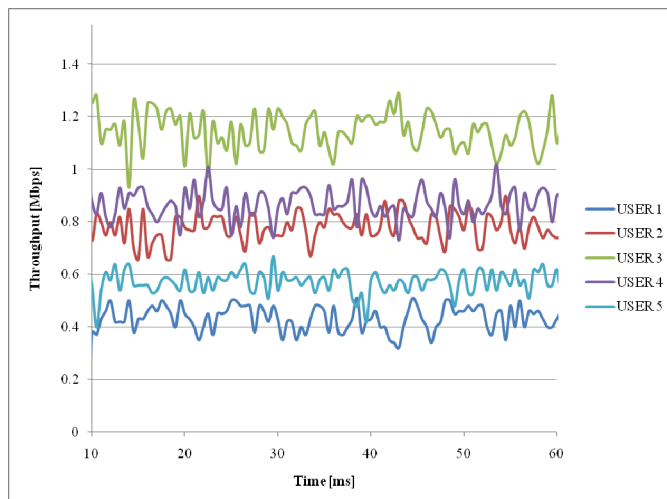

Figure 5 - Streaming session throughput with D-QOAS for 5 heterogeneous connected users

REFERENCES

- [1] H. Liao, H. Lu, “The role of experience and innovation characteristics in the adoption and continued use of E-learning websites,” in *Computers & Education*, vol. 51, Issue 4, 2008, pp. 1405–1416.
- [2] G. Flood, “Make it specific,” in *Human resources*, pp. 64–66, 2006.
- [3] Enterprise Ireland, “Irish learning solutions,” 2009 Available: <http://www.enterprise-ireland.com>
- [4] J. Padhye, J. Kurose, D. Towsley and R. Koodli, “A model based TCP friendly rate control protocol,” in *Proc. NOSSDAV*, 1999.
- [5] D. Sisalem and A. Wolisz, “LDA + TCP-friendly adaptation: A measurement and comparison study,” in *Proc. NOSSDAV*, 2000.
- [6] G.-M. Muntean, P. Perry and L. Murphy, “Subjective Assessment of the Quality-Oriented Adaptive Scheme”, in *IEEE Trans. on Broadcasting*, vol. 51, no. 3, Sept. 2005.
- [7] G.-M. Muntean and N. Cranley, “Resource Efficient Quality-Oriented Wireless Broadcasting of Adaptive Multimedia Content,” in *IEEE Trans. on Broadcasting*, vol. 53, no. 1, Mar. 2007.
- [8] C. H. Muntean and G.-M. Muntean, “Open corpus architecture for personalised ubiquitous e-learning,” in *ACM Personal and Ubiquitous Computing Journal*, 2007.
- [9] L. Qiong and M. van der Schaar, “Providing adaptive QoS to layered video over wireless local area networks through real-time retry limit adaptation,” *IEEE Trans. Multimedia*, vol. 6, no. 2, Apr. 2004.
- [10] S. H. Shah, K. Chen, and K. Nahrstedt, “Dynamic bandwidth management for single-hop ad hoc wireless networks,” in *Proc. IEEE Int’l. Conf. Pervasive Comp. and Commun.*, Dallas-Fort Worth, USA, Mar. 2003.
- [11] K.-A. Cha, “Content complexity adaptation for MPEG-4 audio-visual scene,” *IEEE Trans. Cons. Elec.*, vol. 50, no. 2, pp. 760–765, May 2004.
- [12] M. van der Schaar and H. Radha, “Adaptive motion-compensation finegranular-scalability (AMC-FGS) for wireless video,” *IEEE Trans. Circuits Syst. Video Technol.*, vol. 12, no. 6, pp. 360–371, Jun. 2002.
- [13] N. Cranley, L. Murphy, and P. Perry, “Optimum adaptation trajectories for streamed multimedia,” in *ACM Multimedia Sys. J.*, New York: Springer-Verlag, 2005.
- [14] G. Ghinea and J. Thomas, “QoS impact on user perception and understanding of multimedia video clips,” in *Proc. ACM Multimedia*, Bristol, United Kingdom, 1998, pp. 49–54.
- [15] NOAH NS-extension, <http://icapeople.epfl.ch/widmer/uwb/ns-2/noah/>
- [16] G.-M. Muntean, “Efficient Delivery of Multimedia Streams Over Broadband Networks using QOAS,” in *IEEE Trans. on Broadcasting*, vol. 52, no. 2, June 2006.
- [17] C. H. Muntean, J. McManis, “End-user Quality of Experience oriented adaptive e-learning system”, *Journal of Digital Information, Special Issue on Adaptive Hypermedia*, 7 (1), 2006, <http://journals.tdl.org/jodi/issue/view/29>.